

# SPACE-RAY®

## Double Linear Radiant Tube Heaters

EcoDesign compliant

Model Ratings 30kW to 94kW



[www.spaceray.co.uk](http://www.spaceray.co.uk)

Available in  
NG and LPG

*Power of Two heaters  
– convenience of one flue*

- Efficient and cost saving heating method  
WITH FUEL SAVINGS UP TO 25% VS WARM AIR
- Six model ratings: 30kW to 94kW linear models
- Heat treated Aluminized Calorized steel tubes for improved emissivity and a flake free work environment.
- Aluminium reflectors – a tested and proven superior material – designed to maximise downward radiation
- Lightweight construction - easy assemble and fit.
- Suction operation for increased efficiency and ease of venting - vertical or horizontal.
- Mounting heights from 2.1m to 15m.



# SPACE-RAY®



# Heating Systems



# SPACE-RAY

### SPECIFICATION GUIDE - DOUBLE LINEAR RADIANT TUBE HEATERS

Model No.	LRDL15	LRDL25	LRDL30	LRDL35	LRDL40	LRDL45
Input Rating kW	30.0	46.0	58.0	69.0	84.4	94.0
Length mm - A	10763	19802		25948		
Width mm - B	340					
Height mm - C	180					
Heater Weight Kg	60	92	124	124	158	158
Gas Connection	R - 1/2" BSP Internal					
Supply Pressure	Natural Gas – 2H G20 20mbar, Propane – 3P G31 37mbar					
Electrical Supply	230v~50Hz 125W, Current rating 0.74A, fuse externally (each burner) 3A					
Min Flue Diameter	125mm			150mm		

### MINIMUM CLEARANCES TO COMBUSTIBLE MATERIAL - MM

Model No.	Side	Above	Below	End	Front	Rear
LRDL 15/25	510	450	1220	510	610	305
LRDL 30/35/40/45	760	610	2285	610	760	380

### RECOMMENDED MOUNTING HEIGHT RANGE (General guidance only) M

Model No.	LRDL15	LRDL25	LRDL30	LRDL35	LRDL40	LRDL45
Horizontal	2.5-6.0	3.0-8.0	3.8-10.0	4.0-12.5	4.8-13.5	5.6-15.0
Angle 30°	2.1-4.5	2.7-5.0	3.3-7.0	3.7-8.0	4.0-9.0	4.8-11.0

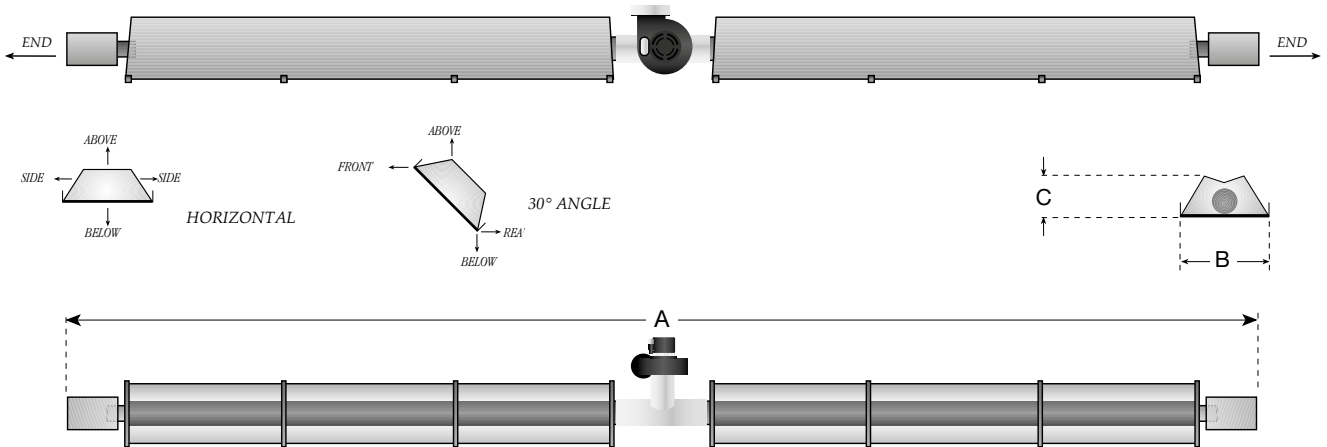

# SPACE-RAY®

For more information contact:

Distributor/Agent:

Gas Fired Products (UK) Ltd, Chapel Lane, Claydon, Ipswich, Suffolk IP6 0JL UK  
Telephone: (01473) 830551 Fax: (01473) 832055 Email: info@spaceray.co.uk Website: www.spaceray.co.uk

We reserve the right to alter specifications without prior notice.

**FACTORIES: ■ IPSWICH, ENGLAND ■ CHARLOTTE, N.C., U.S.A.**



# SPACE-RAY®

## LRU/LRL Radiant Tube Series

*Part L 2010 compliant*

- Six input ratings: 15kW to 47kW available in Linear and 'U' models
- 'Herringbone' link flue systems available with all 'U' and Linear models
- Heat treated Aluminised Calorised emitter tube surface - for flake free and cleaner working environment
- Natural Gas and Propane
- **Aluminium reflectors** - the tested and proven superior material - designed to maximise downward radiant heating effect
- Lightweight construction - **4" tubes supplied in 3m sections** - easy to assemble and fit
- CE Approved
- Efficient and cost saving heating method
- Made in the UK under our ISO9001:2008 quality assured system - all units test fired before despatch

[www.spaceray.co.uk](http://www.spaceray.co.uk)



**SPACE-RAY® Heating Systems**



SPECIFICATION GUIDE - <b>LRU/LRL SERIES PART L 2010 COMPLIANT</b>												
Model No.	LRU15	LRU 25	LRU 30	LRU 35	LRU 40	LRU 45	LRL 15	LRL 25	LRL 30	LRL 35	LRL 40	LRL 45
Heat Input, kW Hs	15.0	23.0	29.2	34.5	42.2	47.0	15.0	23.0	29.2	34.5	42.2	47.0
Heat Input, kW Hi	13.5	20.7	26.3	31.1	38.0	42.3	13.5	20.7	26.3	31.1	38.0	42.3
Length mm - A	3100	5385	5510		6970		5495	10065	9955		13000	
Width mm - B	460		715				460	340				
Height mm - C	175		210				175	180				
Weight Kg	31	47	66		81		27	46	62		79	
Gas Connection	R - 1/2											
Supply Pressure	Natural Gas - 20mbar Propane - 37mbar											
Electrical Supply	230v~50Hz 125W, Current rating 0.55A, fuse externally 3A											
Flue Diameter	127mm Dia. or 100mm Dia.											
Air Inlet Connection	101.6mm Dia.											

RECOMMENDED MOUNTING HEIGHT RANGE (General guidance only)						
Model No.	LRU/LRL 15	LRU/LRL 25	LRU/LRL 30	LRU/LRL 35	LRU/LRL 40	LRU/LRL 45
Horizontal m	2.4 - 6.0	3.0 - 8.0	3.8 - 10.0	4.0 - 12.5	4.8 - 13.5	5.6 - 15.0
Angled > 30° m	2.1 - 4.5	2.7 - 5.0	3.3 - 7.0	3.7 - 8.0	4.0 - 9.0	4.8 - 11.0

MINIMUM CLEARANCES TO COMBUSTIBLE MATERIAL - MM						
Model No.	SIDE	ABOVE	BELOW	END	FRONT	REAR
LRU/LRL 15	450	450	1220	450	575	305
LRU/LRL 25	510	450	1220	510	610	305
LRU/LRL 30 - 45	760	610	2285	610	760	380

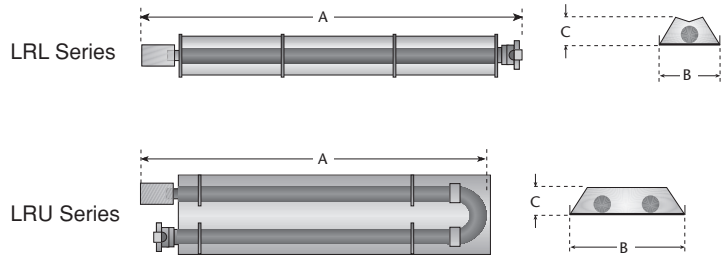
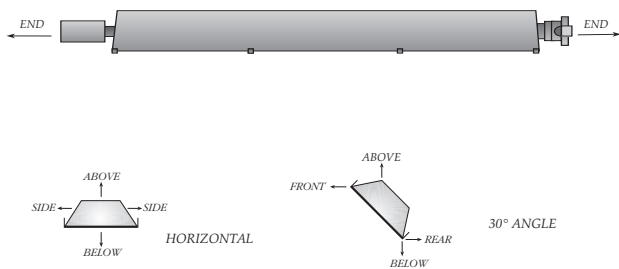

For more information contact:

Distributor/Agent:

Gas Fired Products (UK) Ltd, Chapel Lane, Claydon, Ipswich, Suffolk IP6 0JL UK  
 Telephone: (01473) 830551 Fax: (01473) 832055 Email: info@spaceray.co.uk Website: www.spaceray.co.uk

We reserve the right to alter specifications without prior notice.

**FACTORIES: ■ IPSWICH, ENGLAND ■ CHARLOTTE, N.C., U.S.A.**

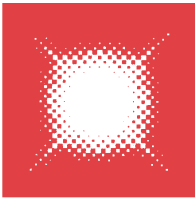

# SPACE-RAY®

## LRU/LRL-HB 'Herringbone' Linked Flue System

*Part L 2010 compliant*

- Six input ratings: 15kW to 47kW available in Linear and 'U' models
- 'Herringbone' manifold links multiple heaters and flues via a single exhaust fan and outlet
- Heat treated Aluminised Calorised emitter tube surface - for flake free and cleaner working environment
- Natural Gas and Propane
- Aluminium reflectors - the tested and proven superior material - designed to maximise downward radiant heating effect
- Lightweight construction - 4" tubes supplied in 3m sections - easy to assemble and fit
- CE Approved
- Purpose designed radiant heating system for efficient, cost saving heating and coverage of large floor areas
- Made in the UK under our ISO9001:2008 quality assured system - all units test fired before despatch

[www.spaceray.co.uk](http://www.spaceray.co.uk)



**SPACE-RAY® Heating Systems**





## SPECIFICATION GUIDE - LRU/LRL-HB SERIES PART L 2010 COMPLIANT

Model No.	LRU 15-HB	LRU 25-HB	LRU 30-HB	LRU 35-HB	LRU 40-HB	LRU 45-HB	LRL 15-HB	LRL 25-HB	LRL 30-HB	LRL 35-HB	LRL 40-HB	LRL 45-HB
Heat Input, kW Hs	15.0	23.0	29.2	34.5	42.2	47.0	15.0	23.0	29.2	34.5	42.2	47.0
Heat Input, kW Hi	13.5	20.7	26.3	31.1	38.0	42.3	13.5	20.7	26.3	31.1	38.0	42.3
Length mm - A	3100	5385	5510		6970		5230	10065	9955		13000	
Width mm - B	460		715				460	340				
Height mm - C	175		210				175	180				
Weight Kg	29	47	66		81		25	46	62		79	
Gas Connection	R - 1/2											
Supply Pressure	Natural Gas - 20mbar Propane - 37mbar											
Electrical Supply	230v~50Hz 125W, Current rating 0.55A, fuse externally 3A											
Air Inlet Connection	101.6mm Dia.											

## RECOMMENDED MOUNTING HEIGHT RANGE (General guidance only)

Model No.	LRU/LRL 15-HB	LRU/LRL 25-HB	LRU/LRL 30-HB	LRU/LRL 35-HB	LRU/LRL 40-HB	LRU/LRL 45-HB
Horizontal m	2.4 - 6.0	3.0 - 8.0	3.8 - 10.0	4.0 - 12.5	4.8 - 13.5	5.6 - 15.0
Angled > 30° m	2.1 - 4.5	2.7 - 5.0	3.3 - 7.0	3.7 - 8.0	4.0 - 9.0	4.8 - 11.0

## MINIMUM CLEARANCES TO COMBUSTIBLE MATERIAL - MM

Model No.	SIDE	ABOVE	BELOW	END	FRONT	REAR
LRU/LRL-HB 15	450	450	1220	450	575	305
LRU/LRL-HB 25	510	450	1220	510	610	305
LRU/LRL-HB 30 - 45	760	610	2285	610	760	380

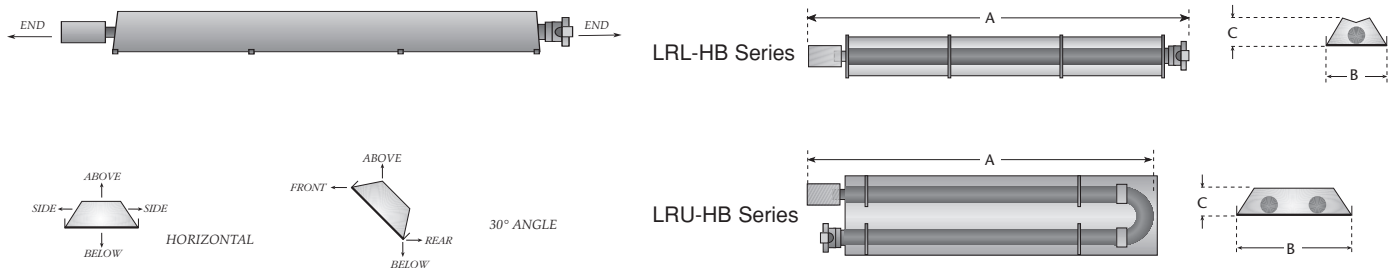

For more information contact:

Distributor/Agent:

Gas Fired Products (UK) Ltd, Chapel Lane, Claydon, Ipswich, Suffolk IP6 0JL UK

Telephone: (01473) 830551 Fax: (01473) 832055 Email: info@spaceray.co.uk Website: www.spaceray.co.uk

We reserve the right to alter specifications without prior notice.

**FACTORIES: ■ IPSWICH, ENGLAND ■ CHARLOTTE, N.C., U.S.A.**